

# Stratlock Range

## SL-RLE

The Stratlock Rail System (SL-RLE), is a versatile panel mounting solution designed for efficient and accurate framework, and allows for offsite prefabrication and installation, including both vertical and horizontal framing. The Stratlock Rail System is ideal for heavy-duty mounting applications and is commonly used for commercial interior fit-outs, a wide range of architectural applications, and is suitable for both wall and ceiling panels.

The Stratlock Rail System is designed to be used with the SL-FA, SL-FB1, and SL-SMT1 female clips, along with the compatible SL-M10 and SL-M18 male clips, offering either a 10kg (22lb) or 18kg (40lb) pull out load. The SL-M18 male clip is also available in a fire-rated version (SL-M18-FR).

The Stratlock Rail System features connectors, including the option of either metal connectors SL-RCF90 and SL-RCAB180 or plastic connectors SL-C-WW90-FR and SL-C-WC90-FR. These connectors are used in conjunction with the Stratlock Rail to enable the extension of rails, create horizontal and vertical framing, and build a wall and/or ceiling grid system. The plastic SL-C-WW90-FR and SL-C-WC90-FR connectors are also fire-rated.

The Stratlock Rail System, in conjunction with the SL-FA and SL-FB1 female clips, features a 360-degree adjustability function, allowing for precise positioning of panels before locking into place via a 2-stage engagement process. The adjustability allows panel adjustment of 8mm (3/8") before locking panels into place.

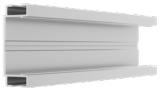

**SL-RLE**  
STRATLOCK RAIL  
EXTRUSION

**USE WITH:**

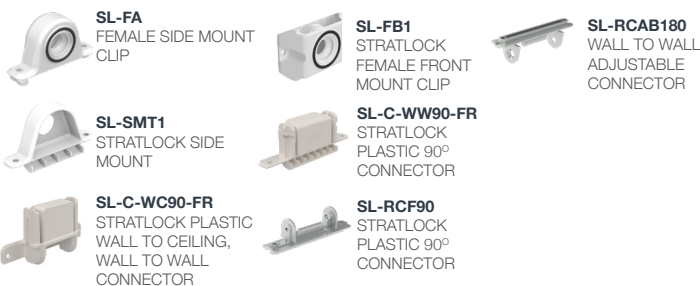

## FEATURES



**Adaptability**

Allows for interior panels to be mounted into drywall, concrete/brick or plywood, making it suitable for a wide range of applications, while also being suitable for uneven surfaces.



**Suspended Ceiling**

Enables enhanced flexibility and easy access to utilities and wiring above the ceiling.



**Non-Sequential Removability**

Offers the advantage of non-sequential removability, allowing panels to be detached in any order for greater flexibility during maintenance and adjustments.



**Heavy-Duty Mounting**

Robust, allowing for heavy panel mounting and suitable for heavy duty applications.



**Rework Reduction**

The Stratlock Rail System allows for panels to be worked off-site, which can help eliminate panel damage and reduce re-work.

## APPLICATIONS

- Commercial fit-outs (retail and offices)
- Hospitality
- Healthcare
- Education
- Wall and ceiling panels
- Suspended ceilings

*\*Not suitable for glass and fibre-cement panels.*

# Stratlock Range

## SL-RLE

### TECHNICAL DATA

#### STRATLOCK RAIL



**SL-RLE**  
MATERIAL: ALUMINIUM

#### CONNECTORS



**SL-RCF90**  
MATERIAL: ALUMINIUM



**SL-RCAB180**  
MATERIAL: ALUMINIUM



**SL-C-WW90-FR**  
MATERIAL: GRILON

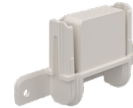

**SL-C-WC90-FR**  
MATERIAL: GRILON

For technical data of all compatible female and male clips, please refer to the Data Sheets for the following:

SL-FA  
SL-FB1  
SL-SMT1

The SL-FA and SL-FB1 Data Sheets also include technical data for all Stratlock Range male clips.

#### SL-RLE DIMENSIONS

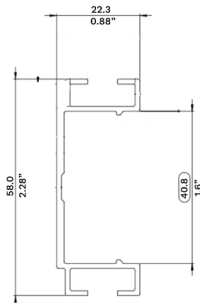
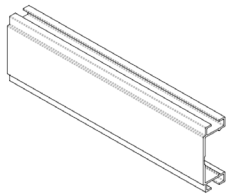

#### DIMENSIONS

For dimensions of all compatible female clips, please refer to the Data Sheets for the following:

SL-FA  
SL-FB1  
SL-SMT1

The SL-FA and SL-FB1 Data Sheets also include the dimensions for all Stratlock Range male clips.

#### ADJUSTABILITY

The use of the SL-RLE along with the SL-FA and SL-FB1 clips, allows for a total of 8mm (3/8") adjustability or 4mm (5/32") in any lateral direction before locking into the final position. This is done via a 2-stage engagement process.

# Stratlock Range

## SL-RLE

### INSTALLATION OPTIONS

#### SL-RLE

The SL-RLE can be installed onto a variety of different substrates, including drywall (into studs behind), concrete/brick and plywood. The SL-RLE can also be installed to create a stand-off from the wall.

The below image relates to drywall, concrete/brick and plywood.

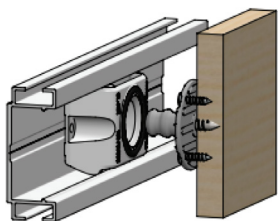

#### DRYWALL

Installed using #8 CSK screws.

(The length of the screws should be determined based on the distance required to securely reach the stud support behind the drywall surface). SL-RLE must be fixed through the drywall, and into stud supports behind.

#### CONCRETE/BRICK

Installed using appropriate concrete screws/anchors.

(The selection of concrete fixings for securing the SL-RLE should be based on the specific requirements of the application).

#### PLYWOOD

Installed using #8 25mm (1") long CSK screws.

For installation options of the compatible SL-FA, SL-FB1, and SL-SMT1 clips, please refer to their respective Data Sheets.

#### CONNECTORS

##### T CONNECTION (PLASTIC)

Installed using #8 16mm (0.63") pan head screws.

The SL-C-WW90-FR is used in conjunction with the SL-RLE to create a T connection.



SL-C-WW90-FR  
MATERIAL: PLASTIC

##### T CONNECTION (METAL)

Installed using supplied grub screws and 2.5mm (0.1") hex key.

The SL-RCF90 is used in conjunction with the SL-RLE to create a T connection.



SL-RCF90  
MATERIAL: ALUMINIUM

##### CORNER CONNECTION (PLASTIC)

Installed using #8 16mm (0.63") pan head screws.

The SL-C-WC90-FR can be used in conjunction with the SL-RLE to create both a wall and ceiling corner connection.



SL-C-WC90-FR  
MATERIAL: PLASTIC

##### ADJUSTABLE CORNER CONNECTION (METAL)

Installed using supplied grub screws and 2.5mm (0.1") hex key.

The SL-RCAB180 is paired with the SL-RCF90 and used with the SL-RLE to create an adjustable corner connection.



##### RAIL EXTENSION

The SL-RCF90 is paired with another SL-RCF90 (one on each side) and used with the SL-RLE to create an extension of two rails.

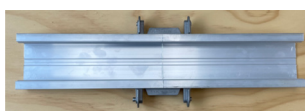

# Stratlock Range



## SL-RLE

### INSTALLATION STEPS

The below installation step guide covers the installation of the SL-RLE and corresponding male clip for all three applications:

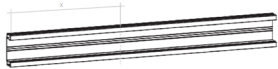

- Drywall
- Concrete/brick
- Plywood

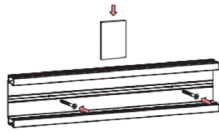
#### INSTALL SL-RLE

- 1** Cut rail to desired length.  

- 2** Pre-drill SL-RLE rail using a 3mm (1/8") drill bit.  

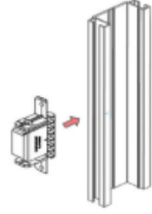
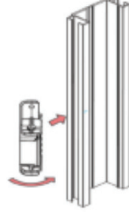
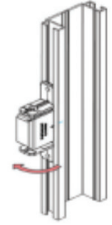
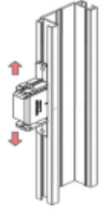
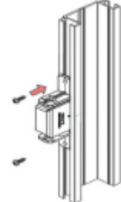
- 3** Fix rail into substitute using appropriate screws and shims/packers if required to level rail.  

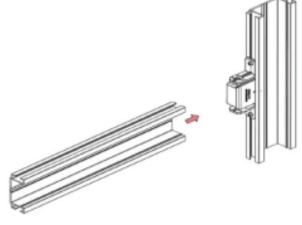
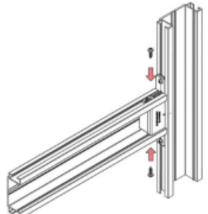
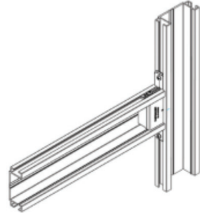
#### INSTALL OPTION 1: PLASTIC CONNECTORS

How to create a T connection using the SL-C-WW90-FR.

- 1** Mark centre positions for SL-C-WW90-FR on SL-RLE.  

- 2** Insert SL-C-WW90-FR into SL-RLE, adjusting SL-C-WW90 until centerlines align.  

- 3** 
- 4** 
- 5** 
- 6** Secure SL-C-WW90-FR in position with 8G self-tapping panhead screws.  

- 7** 
- 8** Slot perpendicular SL-RLE onto SL-C-WW90-FR.  

- 9** 
- 10** 

# Stratlock Range

## SL-RLE

### INSTALL OPTION 2: PLASTIC CONNECTORS

How to create a corner connection using the SL-C-WC90-FR

\*The below steps can be used to create a corner connection for wall to wall or wall to ceiling\*

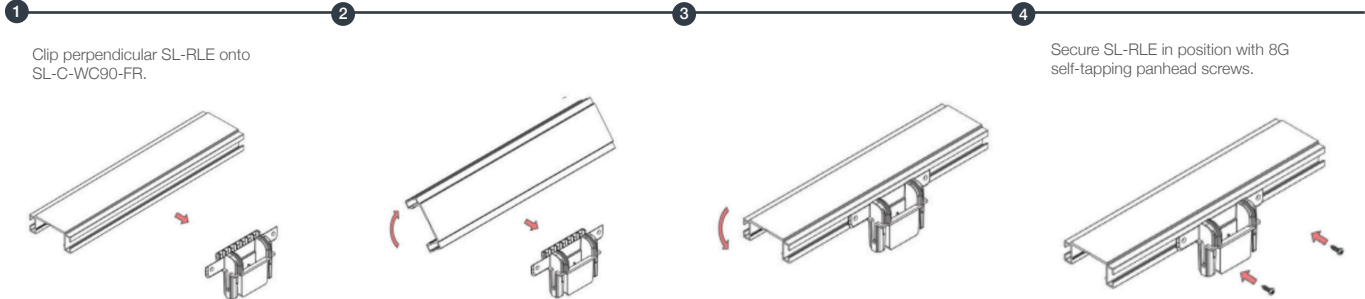

### INSTALL OPTION 3: METAL CONNECTORS

How to create a T connection using the SL-RCF90

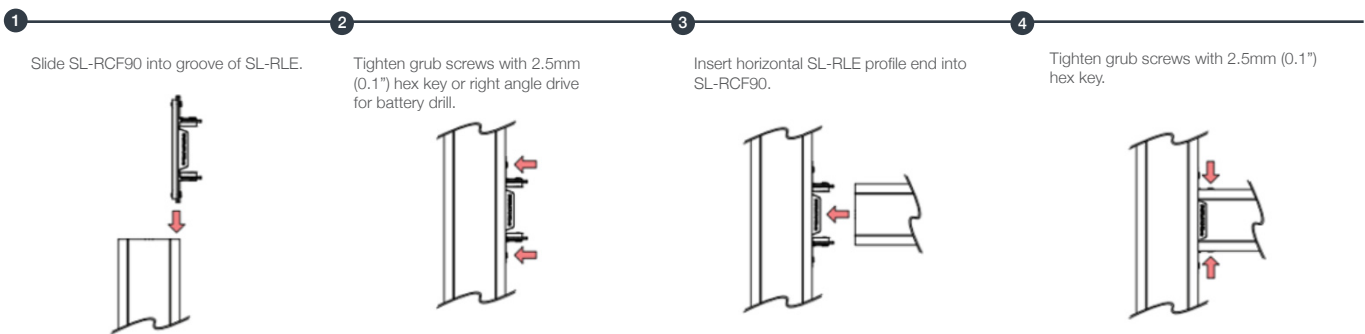

### INSTALL OPTION 4: METAL CONNECTORS

How to create an adjustable corner connection using the SL-RCAB180 and SL-RCF90

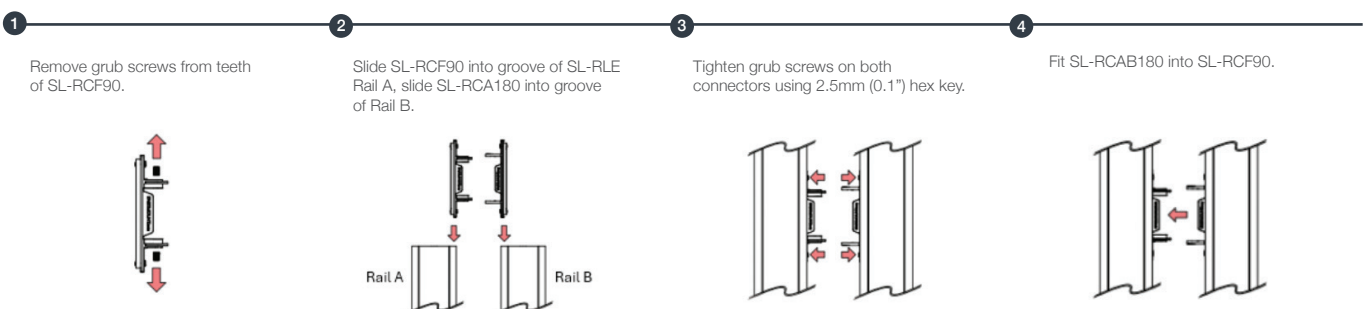

# Stratlock Range

## SL-RLE

5

Insert socket screws to fasten connectors together.

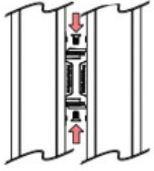

6

Adjust rails to desired corner angle.



7

Tighten socket screws using 3mm (0.12") hex key.



## REMOVING PANELS

Fastmount also provide panel removal tools which can help make the removal of panels easier.



**CT-05**  
Stainless steel removal tool, for removing upholstered panels. Requires a minimum gap of 3mm (0.12").



**CT-05H**  
Stainless steel removal tool with fold down hook, for use with lacquered and/or textured panels. Hook requires a minimum gap of 1mm (0.04").



**CT-17**  
Suction cup sucker tool, for removing heavier panels or painted/pre-finished panels. Two required for controlled panel removal.